

# MANUEL D'INSTRUCTION

**LUTECH  
ÉNERGIE**

**(514) 267-4237**

CLIMATISATION

RÉFRIGÉRATION

VENTILATION

CHAUFFAGE

PISCINE

[WWW.LUTECHENERGIE.COM](http://WWW.LUTECHENERGIE.COM)



## ENERGY MANAGEMENT SYSTEM

### Communicating thermostat

RS-485 - Modbus - LonWorks

# CCTHV-100



## Description

The CCTHV-100 thermostat from Cristal Controls is a stand alone thermostat or is communicating on an RS-485 network and has up to 3 outputs: 2 pulsed outputs and a dry contact output. It also has 2 dry contact inputs and it is possible to tie in a remote sensor for reading of a second temperature sensor (10K).

In stand alone mode the thermostat works as a standard electronic thermostat. With its RS-485 communication capabilities, the CCTHV can:

1. be linked to a Lonworks interface card (Cristal Controls model CCTI-RS485), which enables visualization and control of thermostats on a **LON network**. Up to 24 thermostats can be connected per interface. (see *LON typical installation* section)
2. be linked to a **Modbus** master controller, which enables direct access to the thermostat's parameters without using an interface. Up to 31 thermostats can be connected per master controller. (see *Modbus typical installation* section)

## Features

- 2 pulsed outputs or 2 0-10 VDC outputs
- 1 dry contact output
- 2 dry contact inputs
- 1 remote sensor input
- RS-485 network communication
- Low voltage 24 VAC supply



*Thermostat CCTHV-100*

## Communicating thermostat

RS-485 - Modbus - LonWorks

# CCTHV-100

### Applications

1. Typically, the CCTHV-100 thermostat is used to control modulation of heating elements as well as cooling permission with its dry contact output. The two triac outputs can be controlled separately with the addition of a second temperature sensor; then, two set points can be adjusted.
2. The inputs from the thermostat are used to connect the Vigilance system (see *Appendix 1 – Description of the Vigilance System*), which is an option on Cristal Controls' LS-2000 system.
3. The thermostat uses an open protocol to transfer information. Cristal Controls' CCTI-RS485 interface card uses this protocol to send and receive information from thermostats and make it available on a Lonworks network. It is then possible to offer a more than affordable Lonworks multi-point control solution.
4. The thermostat can also use the standard Modbus communication protocol. In this way, a master controller is able to interrogate each slave thermostat to visualize certain data or configure certain parameters.
5. On request, inputs and outputs of the thermostat can be exploited in other ways.

## Communicating thermostat

RS-485 - Modbus - LonWorks

# CCTHV-100

## Models

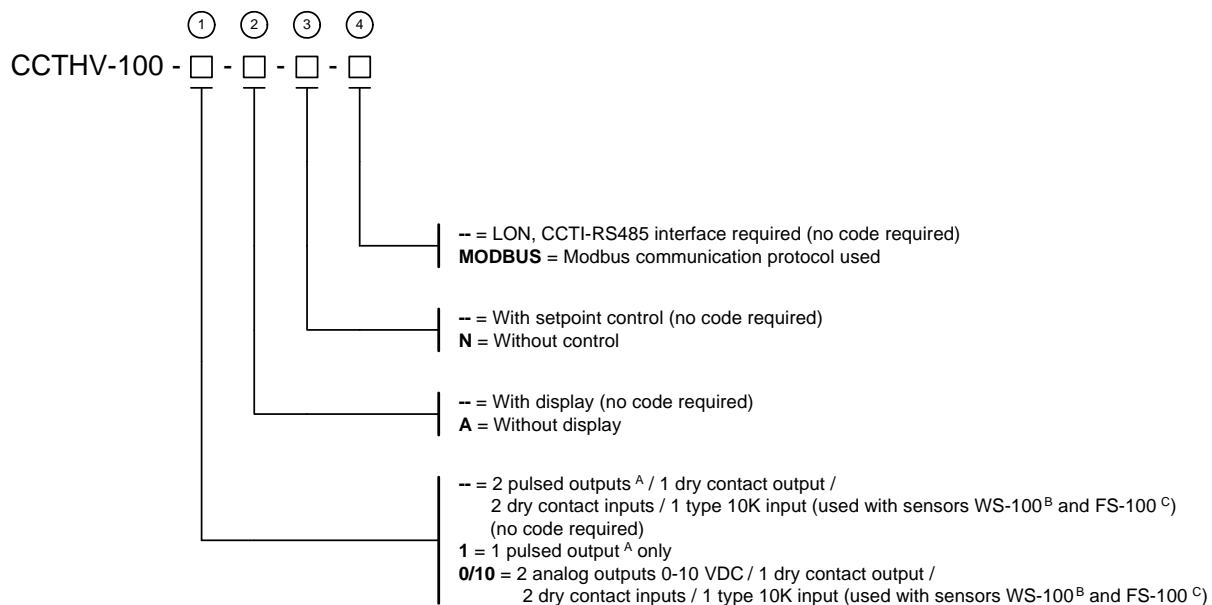

Four options are offered for the CCTHV-100 :

1. Thermostat with 0-10 VDC analog outputs or a reduced version having only one triac output.  
Ex. : CCTHV-100-0\_10 or CCTHV-100-1
2. Thermostat without display.  
Ex. : CCTHV-100-A
3. Thermostat without control knob. (*Useful for common areas*)  
Ex. : CCTHV-100-N
4. Thermostat with Modbus standard communication protocol.  
Ex. : CCTHV-100-MODBUS

**NOTE** : It is possible to combine the options. For example, a non-reduced thermostat without neither display nor control knob could be installed in a common area and be remotely controlled by a building management software. (Ex : CCTHV-100-A-N)

A : Pulsed output working with Cristal Controls' CCT series triacs.

B : WS-100 = Blind wall sensor (see *Appendix 2*)

C : FS-100 = Wall sensor (see *Appendix 2*)

## Communicating thermostat

RS-485 - Modbus - LonWorks

# CCTHV-100

### Technical specifications

#### Supply

- 18 – 24 VAC / VDC
- Consumption : 30mA typical, 60mA max.

#### Outputs

- Pulsed type (500mA or 2 X 250mA @ 24 VAC) or 0-10 VDC analog type (5mA max.)
- Dry contact type, 1A @ 24 VAC

#### Inputs

- Dry contact type
- Temperature input for a 10K sensor (curve 1)

#### Environment

- Operating temperature: 0°C to 40°C (59°F to 86°F)
- 0% to 95% relative humidity without condensation
- Storage temperature: -40°C to 85°C (-40°F to 122°F)
- Temperature reading precision: +/- 0,5°C (+/-0,9°F)
- Display resolution: 0,5°C (1°F)
- Temperature set point available range: 15°C to 30°C (59°F to 86°F)

#### Dimensions

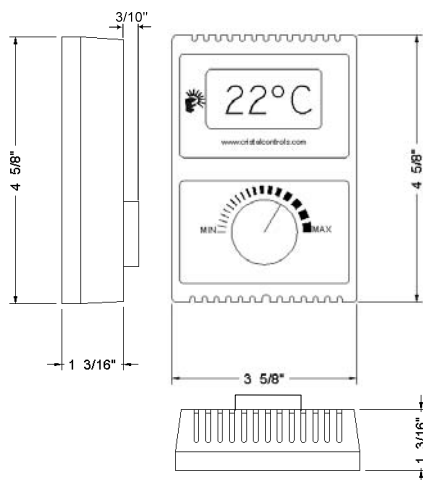

Communicating thermostat  
RS-485 - Modbus - LonWorks  
**CCTHV-100**

LON typical installation (with Lonworks CCTI-RS485 interface)

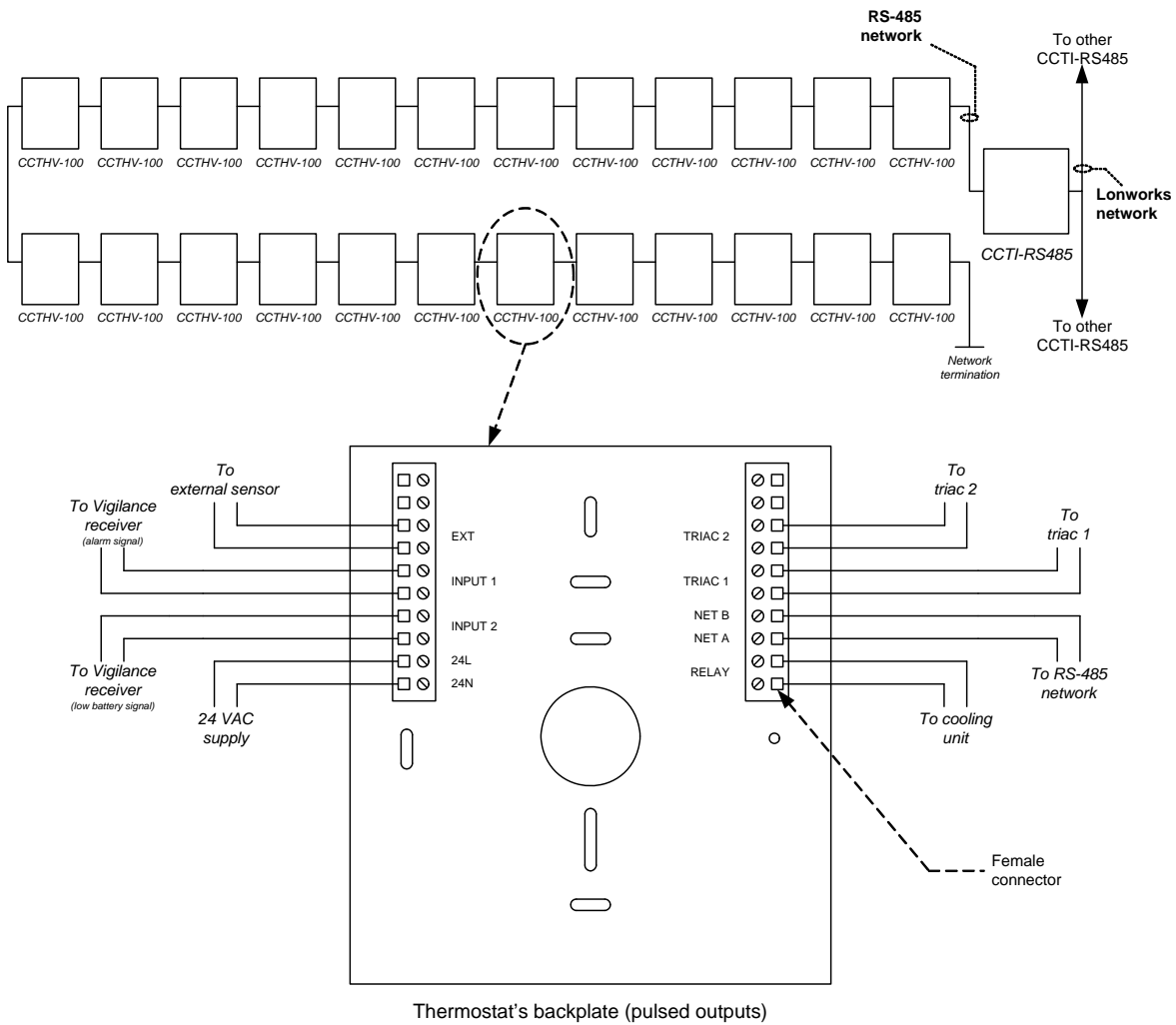

NOTE : Typical installation of a network of CCTHV-100 thermostats (maximum of 24 per sub-network) connected to a CCTI-RS485 interface card, also showing different connections on the thermostat's backplate.

Communicating thermostat  
RS-485 - Modbus - LonWorks  
**CCTHV-100**

## Appendix 1 – Description of the Vigilance System

The Vigilance System from Cristal Controls is an option to the LS-2000 energy management system. It uses the infrastructure of the existing network to send an alarm coming from an RF receiver connected to the thermostat and conveys it to a software installed on the central computer. From the computer, the alarm can also be sent to a cell phone or a beeper.

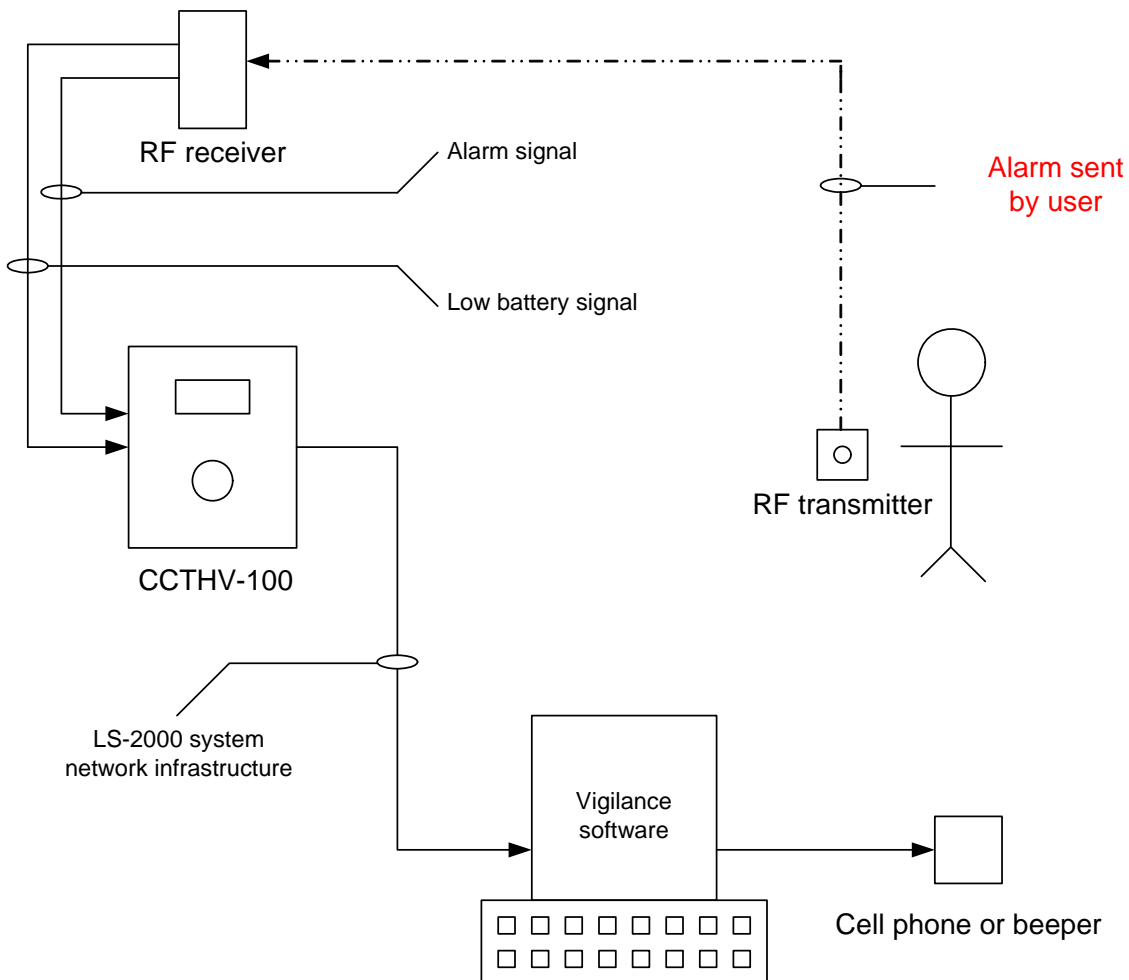

Communicating thermostat

RS-485 - Modbus - LonWorks

**CCTHV-100**

Appendix 2 – WS-100 and FS-100



*WS-100*



*FS-100*