



## SWIMMING POOL HEAT PUMP

### Installation & User Manual

Model      HP40B  
              HP50B  
              HP65B



Hayward Pool Products Canada, Inc.  
T: 1-888-238-7665  
[www.haywardpool.ca](http://www.haywardpool.ca)

# CONTENT

---

<b>I.</b>	<b>Application</b> .....	<b>4</b>
<b>II.</b>	<b>Features</b> .....	<b>4</b>
<b>III.</b>	<b>Technical Parameters</b> .....	<b>5</b>
<b>IV.</b>	<b>Dimensions</b> .....	<b>6</b>
<b>V.</b>	<b>Installation Guide</b> .....	<b>7</b>
<b>VI.</b>	<b>Operation Instruction</b> .....	<b>10</b>
<b>VII.</b>	<b>Testing</b> .....	<b>13</b>
<b>VIII.</b>	<b>Precautions</b> .....	<b>14</b>
<b>IX.</b>	<b>Maintenance</b> .....	<b>15</b>
<b>X.</b>	<b>Troubleshooting</b> .....	<b>15</b>

---

## **WARNING**

---

- A) The Swimming Pool Heat Pump Unit is intended to heat the swimming pool water and regulate the temperature. Use in any other application will void the warranty.
- B) The inlet & outlet connections cannot support any load from another piping system.
- C) Make sure outlet air does not hurt any person, animal & plant.
- D) The unit must always be powered off before opening the access panel. Always cut the unit's main power whenever the access panel is open or removed.

## **PRECAUTIONS**

- A) All electrical connections must be done by a qualified electrician and according to national and local electrical codes. We have provided important safety messages in this manual and on your heater. Always read and obey all safety messages.
- B) You will need to set the water temperature you desire.
- C) Always install the machine outdoors, while respecting the minimal clearances needed for proper operation and heating. DO NOT place the unit next to shrubs, fences, etc. which can block the air inlet. These locations deny the unit a continuous source of fresh air which reduces its efficiency and may prevent adequate heat delivery.
- D) All Hayward Heat Pumps must be installed in accordance with all applicable National and Local codes. In the absence of local codes, refer to the latest edition of the Canadian Electrical Code (CEC).
- E) The unit will automatically start up when there is proper flow and available power.
- F) If the unit is stopped for an extended period of time or winterized, it must be drained of all water. You will need to disconnect the IN and OUT water connections. Then the unit must then be tilted or blown out with air until all water is out.
- G) Do not insert any objects into the air outlet. Do not attempt to disassemble the fan at any time.
- H) If at any time there is an abnormal noise, smell, smoke, electricity leakage, please switch off power immediately and contact your local dealer. All repairs must be performed by a qualified technician.
- I) Do not store combustible or flammable material near unit.

## **I. APPLICATION**

---

1. For your comfort and pleasure, set swimming pool water temperature efficiently and economically.
2. All technical parameters are factory set. Please refer to technical parameter table.

## **II. FEATURES**

---

1. Highly efficient titanium heat exchanger.
2. Sensitive and accurate temperature control and water temp display.
3. Environment-friendly R410A refrigerant.
4. High pressure, low pressure & water flow protection system.
5. Exceeding low temperature auto stop protection.
6. Temperature controlled compulsory defrosting.
7. International brand compressor.
8. Easy installation and operation.

### III. TECHNICAL PARAMETERS

Model	HP40B	HP50B	HP65B
Heating capacity	40000 BTU	50000 BTU	65000 BTU
Cooling capacity	-	29000 BTU	42300 BTU
Voltage	208-230V	208-230V	208-230V
Frequency/phase	60Hz/1Ph	60Hz/1Ph	60Hz/1Ph
Heating current(air80°F,water80°F)	7.7A	10.8A	11.8A
Heating power(air80°F,water80°F)	1.65KW	2.3KW	2.6KW
Heating current(air80°F,water95°F)	9.6A	13.2A	13.3A
Heating power(air80°F,water95°F)	2.0KW	2.7KW	2.9KW
Compressor RLA/LRA	9.7A/34.8A	11.6A/60.2A	12.9A/66.9A
Fan motor rating	0.5A	0.5 A	1.1 A
MCA/MOP	12A/20A	16A/30A	17.2A/30A
Design pressure(High)	≦ 609 PSIG	≦609 PSIG	≦609 PSIG
Design pressure(Low)	≦ 261 PSIG	≦261 PSIG	≦261 PSIG
Refrigerant(R410A)	44.1oz	56.4oz	74.1oz
Net weight	125 lbs / 57 kg	154 lbs / 70kg	172 lbs / 78kg
Water circulation flow	67-100L/min	83-116 L/min	108-142L/min
Noise	Max 50dB(A)	Max 50 dB(A)	Max 58dB(A)
Waterproof class	IPX4	IPX4	IPX4

**Remarks:**

This product has been tested at air temperature of 32°F ~109°F. Efficiency cannot be guaranteed out of these ranges. All parameters will differ under various conditions.

## IV. DIMENSIONS

---

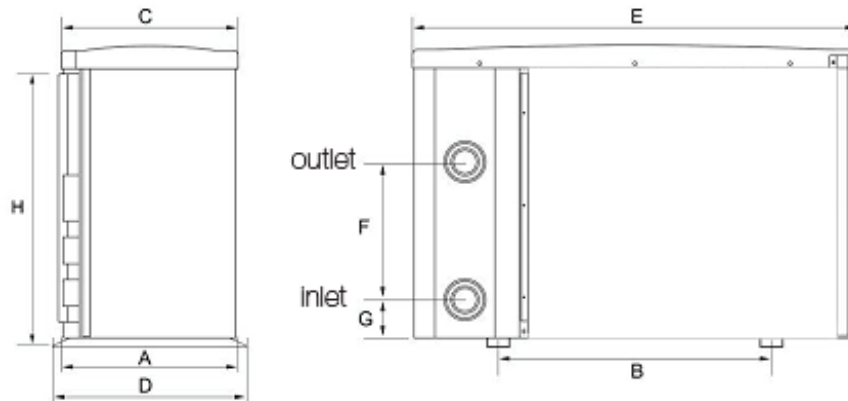

Name Size(mm) Model	A	B	C	D	E	F	G	H
HP40B	312	590	312	340	961	280	70	658
HP50B	392	590	392	420	961	290	84	658
HP65B	392	590	387	420	961	380	84	758

**Note:** The above diagram is the specification diagram of the pool heater, for technician's installation and layout reference only.

# V. INSTALLATION GUIDE

## 1. Diagram for Water Piping Connections

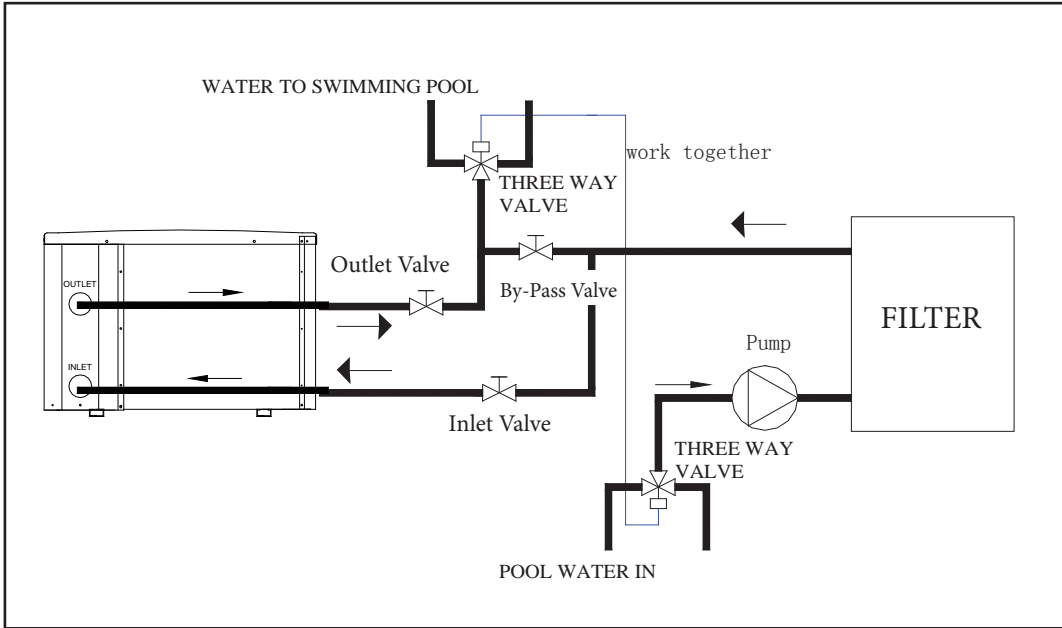

**Note:** The diagram is for demonstration purposes only, and layout of the pipes is for reference only.

## 2. Electric Wiring Diagram

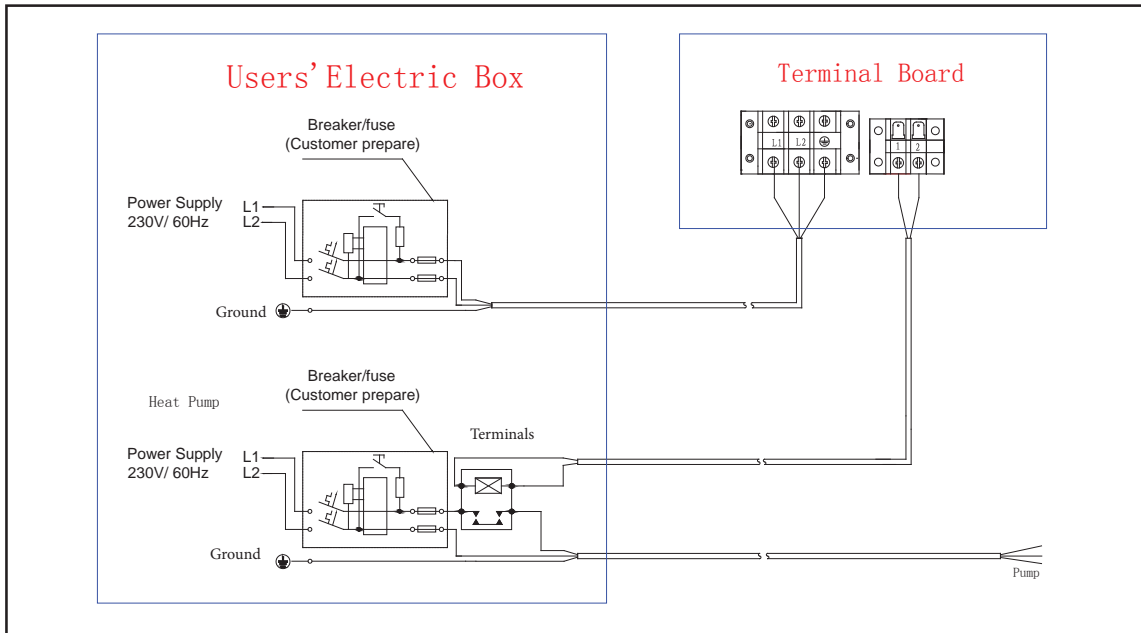

**Note:** The swimming pool heat pump must be grounded.

# V. INSTALLATION GUIDE

---

## Options for protecting devices and cable specification.

Model		HP40B	HP50B	HP65B
Breaker	Rated current A	15	20	25
	Rated Residual Action Current mA	30	30	30
Fuse A		15	20	25
Power cord ( AWG )		3X12	3X12	3X10
Signal cable ( AWG )		3X20	3X20	3X20

**Note:** The above data is for an electrical cord of less than 10 m. If electrical cord is > 10 m, wire diameter must be increased. The signal cable can be at maximum 50 m.

## Pump protecting device, cable specification is subject to user's option.

### 1. Installation Instruction and Requirements:

All electrical connections must be done by a qualified electrician and according to national and local electrical codes. We have provided important safety messages in this manual and on your heater. Always read and obey all safety warnings. All Hayward Heat Pumps must be installed in accordance with all applicable National and Local codes. In the absence of local codes, refer to the latest edition of the Canadian Electrical Code (CEC).

#### A. Installation

1. Always install the machine outdoors, while respecting the minimal clearances needed for proper operation and heating. DO NOT place the unit next to shrubs, fences, etc. which can block the air inlet. These locations deny the unit a continuous source of fresh air which reduces its efficiency and may prevent adequate heat delivery.
2. Mount the unit on a sturdy base, preferably a concrete slab. The base should be completely isolated from the building foundation wall to prevent the possibility of sound or vibration transmission into the building.
3. The pool heat pump is designed for outdoor installation and should not be installed in a fully enclosed area, such as a shed, garage, etc. Recirculation of cold discharged air back into the evaporator coil will greatly reduce unit heating capacity and efficiency.



## V. INSTALLATION GUIDE

---

Air is pulled through the evaporator coil and discharged through the side grille. A minimum clearance of 98 inches should be allowed on the air outlet side for unrestricted air discharge. The unit must not be installed under a porch. Any other side of the unit should be located at least 28 inches from a wall or from any other obstruction for unrestricted air intake and service access.

4. The piping sequence is as follows: pool > pool pump > filter > heater > check valve > chemical feeder > pool. Automated chlorine distribution systems, if used, must be placed downstream of the heater to minimize harm to the pool equipment. Use rigid PVC piping if possible (SCH40 or SCH80). All joints should be glued with PVC glue. When the piping installation is complete, operate the pool pump and check the system for leaks. Then, check the filter pressure gauge to verify that there isn't any indication of excessive pump head pressure.

You can also make the connections using high-pressure flexible hose, but make sure the hose can withstand high pressure. The installation of a heat pump bypass is not necessary unless the water flow exceeds 75 GPM.

5. It is also normal to see water dripping from the drain at the base pan of the unit. While your pool heat pump is in the heating mode, a large volume of warm and humid air passes over the evaporator and causes condensation. To check if there really is a leak, you must stop the heat pump and leave the pool pump running for at minimum 5 hours. If water is still coming out of your heat pump after this period, then call your dealer for service.

### B. Wiring

1. The wiring of your pool heat pump should be performed by a qualified electrician in accordance with local requirements. A properly-sized breaker and copper wire must be used. Check the heat pump data label for required maximum breaker size. Because all metals have different electrical potentials, all metal and electrical components of the pool system must be bonded together. This includes the metal framework of the pool, the light, the pump, the filter (if made out of metal), the heater, any automatic chlorine generator, and any other metal or electrical equipment. On some older pools, this substructure bond wire may not exist. In these cases, a 6 to 8 foot solid copper rod must be driven into the ground near the equipment. All electric and metal components must then be bonded to each other, and then to the copper rod.
2. The wiring of your pool heat pump must be performed by a qualified electrician in accordance with national and local requirements.
3. Set leakage protector according to the local code for wiring (leakage operating current  $\leq 30\text{mA}$ ).
4. The layout of power cable and signal cable should be orderly and not affecting each other.







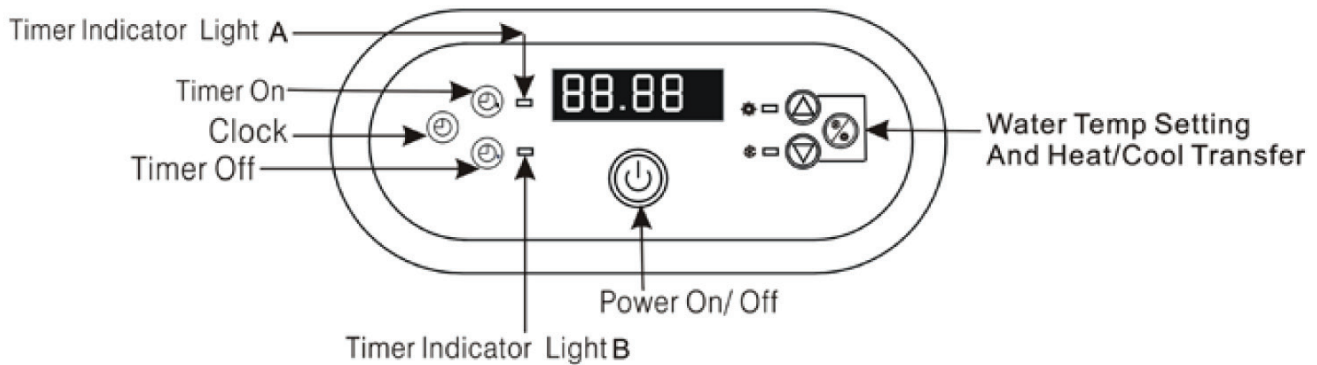





### C. Switch on after finishing all wiring, installation and double checking.

# VI. OPERATION INSTRUCTION

## LED Controller



\*HP40B has no cooling function

-  Power on/off
-  CLOCK Set local time.
-  TIME OFF Set the time required for machine to auto-stop.
-  Light A Shows the auto-stop time being set.
-  TIME ON Set the time required for machine to auto-operate
-  Light B Shows the auto-operate time being set.
-  COOL Shows the cool mode has been set. (only available on the heat and cool machine)
-  HEAT Shows the heat mode has been set.
-  MODE Key Heat or cool mode selection (only available in heat and cool machine)
-  DOWN-ALLOW Set required temperature and time.
-  UP-ALLOW Set required temperature and time.
-  **88.88** LED screen Display time, temperature and machine failure code.

## Permanent Display

- A. The LED screen will display **Time** when the machine is turned off.
- B. The LED screen will display **Water temperature** in swimming pool when the machine is turned on.

## VI. OPERATION INSTRUCTION

---

### Common Setting





#### 1. Heat/Cool Mode

Press the Mode button to switch from one mode to another.

*(Available only in heat and cool machine.)*









#### 2. Required pool water temperature

*It can be adjusted both when the machine is on or off.*

- A. Press UP-ALLOW key  or DOWN-ALLOW key  to set to your required pool water temperature.
- B. The numbers in the LED screen will flash during your operation.
- C. After five seconds, it will stop flashing and be saved, the LED screen will return to the permanent display.
- D. When you want to check the temperature, press UP-ALLOW key  or DOWN-ALLOW key  to see the current setting.

#### 3. Time setting

*It can be adjusted both when the machine is on or off.*

- A. Press  key to set time according to your local time.
- B. Time on the LED screen flashes.
- C. Press  again then press UP-ALLOW key  or DOWN-ALLOW  key to set hour.
- D. Before it stops flashing, press  and then press UP-ALLOW key  or DOWN-ALLOW key  to set minutes
- E. After setting, press  and the water temperature will appears. 30 seconds later, it will stop flashing and the LED screen will return to the permanent display.







# VI. OPERATION INSTRUCTION

---









## Automatic on/off

*This function can make the machine work or stop automatically in your required time.*



### 1. Time on

- A. Press  to set timer on.
- B. When the indicator light is on and the time is flashing , press  again to set hour.  
Use  and  to adjust.
- C. Before the flashing stops, press  to set minute Use  and  to adjust.
- D. After adjusting, press “TIMER ON” and water temperature will be seen. 30 seconds later, the controller display will be back to the normal mode.

### 2. Time off

- A. Press  to set timer off.
- B. When the indicator light is on and the time is flashing , press  again to set hour.  
Use  and  to adjust.
- C. Before the flashing stop, press  to set minute Use  and  to adjust.
- D. After adjusting, press  and water temperature will be seen. 30 seconds later, the controller display will be back to the normal mode.

### 3. Cancelling the automatic mode

- A. Press  or  to cancel timer on and off.
- B. When the number is flashing, press . When timer indicator light is off and LED shows water temperature, the timer on and off is canceled.
- C. 30 seconds later, the controller display will be back to the permanent display.

## Fahrenheit and Celsius Switch

Keep pressing  for 10 second, you can switch the display between Degree Fahrenheit and Degree Celsius, whether the machine is on or off.

# VII. TESTING

---

## 1. Inspection before use

- a. Check installation of the whole machine and the pipe connections according to the pipe connection diagram
- b. Check the electric wiring according to the electric wiring diagram; and make sure the Heat Pump is bonded
- c. Make sure that the main machine power switch is off
- d. Check the temperature setting.
- e. Check the air inlet and outlet.

## 2. Trial

- a. The user must “Start the Pump before the Machine, And Turn off the Machine before the Pump”, or the machine will be damaged
- b. The user should start the pump, check for any water leakage of water; set temperature in the thermostat, and then switch on power supply.
- c. In order to protect the swimming pool heater, the machine is equipped with a time delay starting function, when starting the machine, the blower will run for 3 minutes before the compressor starts.
- d. If at any time there is an abnormal noise, smell, smoke, electricity leakage, please switch off power immediately and contact your local dealer. All repairs must be performed by a qualified technician.

# VIII. PRECAUTIONS

---

## 1. Attention

- a. Set proper temperature in order to get comfortable water temperature; to avoid overheating or over cooling.
- b. Always install the machine outdoors, while respecting the minimal clearances needed for proper operation and heating. DO NOT place the unit next to shrubs, fences, etc. which can block the air inlet. These locations deny the unit a continuous source of fresh air which reduces its efficiency and may prevent adequate heat delivery.
- c. Never put hands or any objects into outlet of the swimming pool heat pump, and don't remove the screen over the fan at any time.
- d. If at any time there is an abnormal noise, smell, smoke, electricity leakage, please switch off power immediately and contact your local dealer. All repairs must be performed by a qualified technician.
- e. Do not use or stock combustible gas or liquids such as paint thinners, paint, fuel near or around the heat pump.
- f. As with all pool heaters, you are advised to use a pool cover at night and when the pool is not in use. The pool cover should be used if night temperatures are 15°F less than desired pool temperature. This will keep evaporation, the greatest source of heat loss, to a minimum, thus greatly reducing the overall pool heating costs. During warmer weather, the pool cover may not be required.
- g. The heat pump should be installed within 10m of the pool to minimize heat loss in the underground pipes.

## 2. Safety

- a. Please keep the main power supply switch out of reach from children.
- b. If there is a power outage while the machine is in operation, the heat pump will start up automatically when power is restored.
- c. Please switch off the main power supply during lightening storms to prevent any damage to the unit.
- d. If the machine is stopped for a long time, please cut off the power supply and drain water of the machine by opening the tap of inlet pipe. If the unit is stopped for a long period of time or for winterizing, the unit must be drained of all its water. You will need to disconnect the IN and OUT water connections. Then the unit must be tilted or blown out with air until all water is out.

## IX. MAINTENANCE

---

- a. Disconnect power supply of the heater before any examination and repair.  
The unit must always be powered off before opening the access panel. Always cut off the unit's main power whenever the access panel is open or removed.
- b. In winter seasons, please drain water clear of the machine, disconnect power supply to prevent any machine damage, and cover the machine body with plastic cover to avoid dust. If the unit is stopped for a long period of time or for winterizing, the unit must be drained of all its water. You will need to disconnect the IN and OUT water connections. Then the unit must be tilted or blown out with air until all water is out.
- c. Please clean this machine with household detergents or clean water, NEVER gasoline, thinners or any similar fuel. The area around the unit should be dry, clean and well ventilated. Clean the side heating exchanger regularly to maintain good heat exchange and conserve energy. Dirt can accumulate on the evaporator. You can easily remove it by using a non-pressured water spray without damaging the small aluminum fins. The cleaning of the plastic cabinet can be done with the help of a brush and soap.
- d. Check bolts, cables and connections regularly.

## X. TROUBLESHOOTING

---

### Common Faults

Faulty	Reason	Solutions
<b>Not starting</b>	Main power is off	Wait for power to be reinstated
	Switch off	Switch on
	Burnt out fuse	Replace it
	Circuit breaker drops out	Switch Circuit Breaker back on
<b>There is air outlet but the heating is not satisfactory</b>	Blocked air inlet	Clean out the stem
	Blocked air outlet	Clean out the stem
	3 minutes time lag protection	Please wait
	Temperature set too low	Increase temperature setting accordingly
If the above mentioned faults cannot be solved, please contact the professional and inform model and detailed faulty condition.		

**ATTN: Do not disassemble or repair the swimming pool heat pump by yourself, contact a licensed technician for service.**

## X. TROUBLESHOOTING

---

NO.	Failure code	Failure description
1	EE 1	High pressure protection
2	EE 2	Low pressure protection
3	EE 3	Low water pressure protection
4	EE 4	Single phase machine : failure connection due to loose wire terminal of PROT2 on the PC board
5	PP 1	Pool water temp sensor failure
6	PP 2	A.Heat only type : Exhaust temp sensor failure B.Cool and Heat type: Cooling coil pipe temp sensor failure
7	PP 3	Heating coil pipe temp sensor failure
8	PP 4	Gas return temp sensor failure
9	PP 5	Air temp sensor failure
10	PP 6	Compressor exhaust overload protection
11	PP 7	When the temperature < 32°F,auto stop for protection (Not Failure )
12	EE8/888 /Messy Code	Communication Failures



# X. TROUBLESHOOTING

## Parts Breakdown

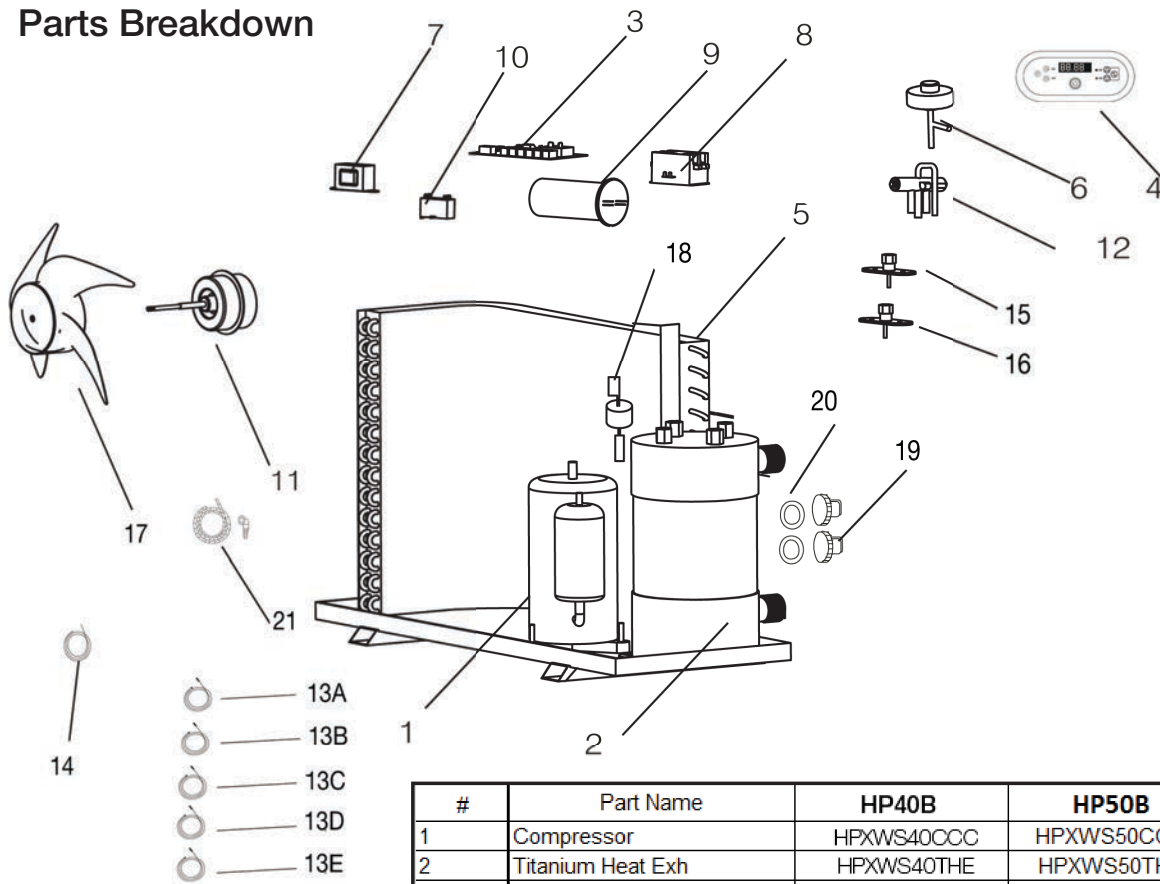

#	Part Name	HP40B	HP50B	HP65B
1	Compressor	HPXWS40CCC	HPXWS50CCC	HPXWS65CCC
2	Titanium Heat Exh	HPXWS40THE	HPXWS50THE	HPXWS65THE
3	PC Board Fairland	HPXWS40PCB	HPXWS56PCB	HPXWS56PCB
4	LCD Controller Fairland	HPXWS40IL	HPXWS56IL	HPXWS56IL
5	Evaporator	HPXWS40E	HPXWS50E	HPXWS65E
6	Expansion Valve	-	HPXWS50EV	HPXWS65EV
7	Fairland Transformer	HPXWS40T	HPXWS56T	HPXWS56T
8	Fairland Contactor	HPXWS40C	HPXWS56C	HPXWS56C
9	Compressor Capacitor	HPXWS40CC	HPXWS56CC	HPXWS56CC
10	Fan Motor Capacitor	HPXWS40FMC	HPXWS50FMC	HPXWS65FMC
11	Fan Electric Motor	HPXWS40FM	HPXWS50FM	HPXWS65FM
12	4- way Valve	HPXWS40FWV	HPXWS56FWV	HPXWS56FWV
13A	Pool water temp sensor	HPXWS40TMP	HPXWS56TMP	HPXWS56TMP
13B	Cooling coil pipe temp sensor	-	HPXWS56TMP	HPXWS56TMP
13C	Heating coil pipe temp sensor	HPXWS40TMP	HPXWS56TMP	HPXWS56TMP
13D	Gas return temp sensor	-	HPXWS56TMP	HPXWS56TMP
13E	Exhaust temp sensor	HPXWS40ETS	-	-
14	Air temp sensor	HPXWS40ATS	HPXWS56ATS	HPXWS56ATS
15	High pressure valve	HPXWS40HPS	HPXWS56HPS	HPXWS56HPS
16	Low pressure valve	HPXWS40LPS	HPXWS56LPS	HPXWS56LPS
17	Fan	HPXWS40F	HPXWS50F	HPXWS65F
18	Water flow Switch	HPXWS40WFW	HPXWS56WFW	HPXWS56WFW
19	Water nozzle	HPXWS40WN	HPXWS56WN	HPXWS56WN
20	Water nozzle Gasket	HPXWS40WNG	HPXWS56WNG	HPXWS56WNG
21	Draining tube & black joint	HPXWS40DTJ	HPXWS56DTJ	HPXWS56DTJ

# WARRANTY

---

## HAYWARD® HEAT PUMP POOL HEATERS LIMITED WARRANTY

The HAYWARD heat pump pool heater is warranted to be free of defects in materials and workmanship for a period of one (1) year for parts and (1) one year for labor.

Warranty is applicable to the original location and owner only and is not transferable. The *compressor* component has a two (2) year limited warranty with parts & labour warranted the first year and parts only warranted in year two.

The *titanium tube* component of the heat exchanger has a five (5) year parts only warranty.

HAYWARD will not void this warranty due to improper pool chemistry.

This warranty is valid only if the product is installed according to the HAYWARD specifications.

This warranty does not include refrigerant or other expendable materials, or services such as inspection, maintenance, or unnecessary service calls due to erroneous operational reports, external valve position, or electrical service. It also does not include the repair of damage due to negligence, accident, freezing, or other conditions beyond the normal intended use of the unit. This warranty is void if the product is repaired or altered in any way by any persons or agencies other than those authorized by HAYWARD, and is in lieu of all other warranties, expressed or implied, written or oral. There are no implied warranties of merchantability or fitness for a particular purpose that apply to this product. This warranty applies only within Canada.

At its option, HAYWARD will replace or repair any HAYWARD part that proves defective if such parts are returned to our factory, freight collect, within the warranty period. It is agreed that such replacement or repair is the exclusive remedy available from HAYWARD. Unless authorized by HAYWARD and performed by a factory authorized service center, HAYWARD is not liable for any labor involved in the removal of defective parts or the installation of replacement parts. HAYWARD is not liable for damages of any sort whatsoever, including incidental and consequential damages. Parts returned and services performed under terms of this warranty must be approved by HAYWARD. All parts returned under terms of this warranty will be repaired or replaced and returned transportation charges prepaid, by best and most economical means.

Hayward Pool Products Canada, Inc.  
2880 Plymouth Dr., Oakville, ON L6H 5R4  
[www.haywardpool.ca](http://www.haywardpool.ca) / 888-238-7665

**Retain this Warranty Certificate in a safe and convenient location for your records**



Hayward Pool Products Canada, Inc.  
T: 1-888-238-7665  
[www.haywardpool.ca](http://www.haywardpool.ca)