

MANUEL D'INSTRUCTION

**LUTECH
ÉNERGIE**

(514) 267-4237

CLIMATISATION

RÉFRIGÉRATION

VENTILATION

CHAUFFAGE

PISCINE

WWW.LUTECHENERGIE.COM



KE2 Switch

Part of the **Refrigeration Network**

Included in the KE2 Switch package:

- KE2 Switch part #20166
- AC power adapter (7.5V DC, 1A)
(not sold separately)
- Bulletin/Installation B.5.2

KE2 Switch



Introduction

The KE2 Switch is a key component of the Refrigeration Network infrastructure. It enables communication between controllers when multiple controllers are installed.

When multiple controllers are attached to a KE2 Switch, once bonded, the KE2 Switch forms the foundation of a local Refrigeration Network. This local Refrigeration Network facilitates communications between controllers, plus provides a path for communications to the Internet. The controllers are linked via an Ethernet cable to the KE2 Switch.

Systems designed utilizing high speed communications are able to provide features of significant importance. Critical data shared by the networked controllers include air sensor readings, suction pressure readings and defrost cycles.

Benefits of KE2 Switch Communication:

Air Sensor - If one controller in the Refrigeration Network experiences a temperature sensor error, the controllers will send the impaired controller either the average temperature or the highest temperature in the space, allowing the controller to continue operating until it can be serviced.*

Suction Pressure - Similar to the sensor reading, suction pressure may be shared if errors are detected. When sharing pressures, the lowest pressure is used to ensure liquid doesn't return to the compressor.*

Defrost Cycles - Coordinating defrost cycles is also extremely important. Depending on the type of defrost method selected, the KE2 Evaporator Efficiency will modify the sequence of operation to maximize the system operation. Electric heating elements require all of the evaporator coils on a single condenser

to defrost simultaneously, while hot gas defrosts require a maximum of 25% of the system to be in defrost at a time, and one evaporator coil in refrigeration mode during the defrost.

In addition to communicating with each other, the controllers can be connected to the Internet. This provides many extra features such as; remote real time status monitoring, set point adjustments, and alert message notifications. With minimal effort, the controller can be configured to send text messages, e-mail messages or SMS alerts to the responsible party to notify them of predetermined cautions provided by the KE2 Evaporator Efficiency. The list of available alarms is located in Bulletin N.1.1.

Specifications

Construction	sturdy metal case
Interface	8 x 10/100/1000Mbps Auto-MDIX RJ-45 ports
Standards	IEEE 802.3 10Base-T IEEE 802.3u 100Base-TX IEEE 802.3ab 1000Base-T IEEE 802.3x Flow Controller
Network Media	Ethernet: CAT. 3,4,5 up to 100m Fast Ethernet: CAT. 5 up to 100m Gigabit Ethernet: 2000Mbps (full-duplex)
Switch Fabric	16 Gbps forwarding capacity
Diagnostic LEDs	Power, Link/AST, Speed

Expanding Network Capacity

A single KE2 Switch provides for 8 controllers, but multiple switches can be stacked which allows for an unlimited number of controllers. Stacking switches uses one port of the primary switch to link to a secondary switch; this method effectively adds 7 ports to the switch, expanding the network capacity.

Linking Switches for Larger Networks

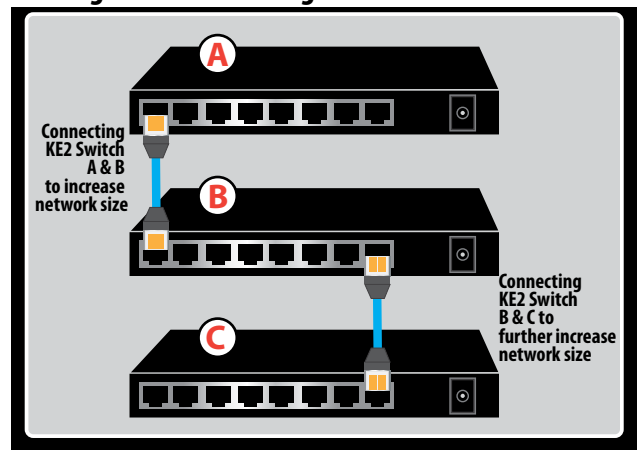

* The controller will continue to alarm via LEDs, and where an internet connection is established also via e-mail notification.

Application

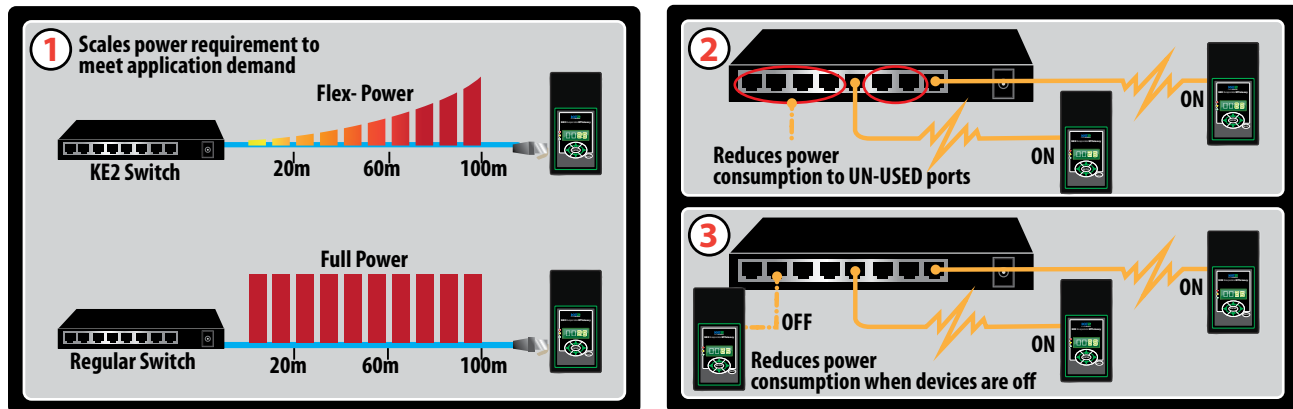

Installation

- KE2 Evaporator Efficiency controller
- CAT-5e or CAT-6 network cable
- Make sure that there is adequate ventilation around the KE2 Switch
- Do not place heavy objects on the KE2 Switch

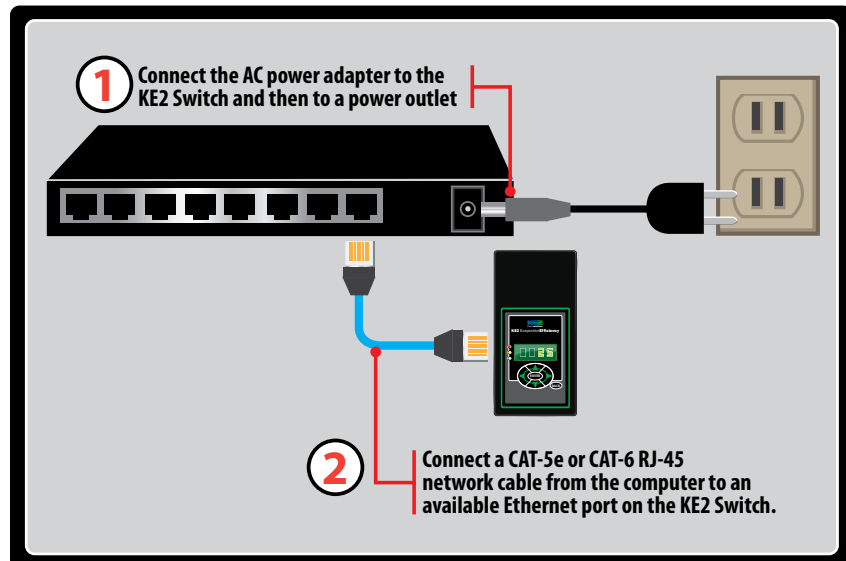

LED Lights

